

ZSM Series of Dental Lab Microscopes User's Manual

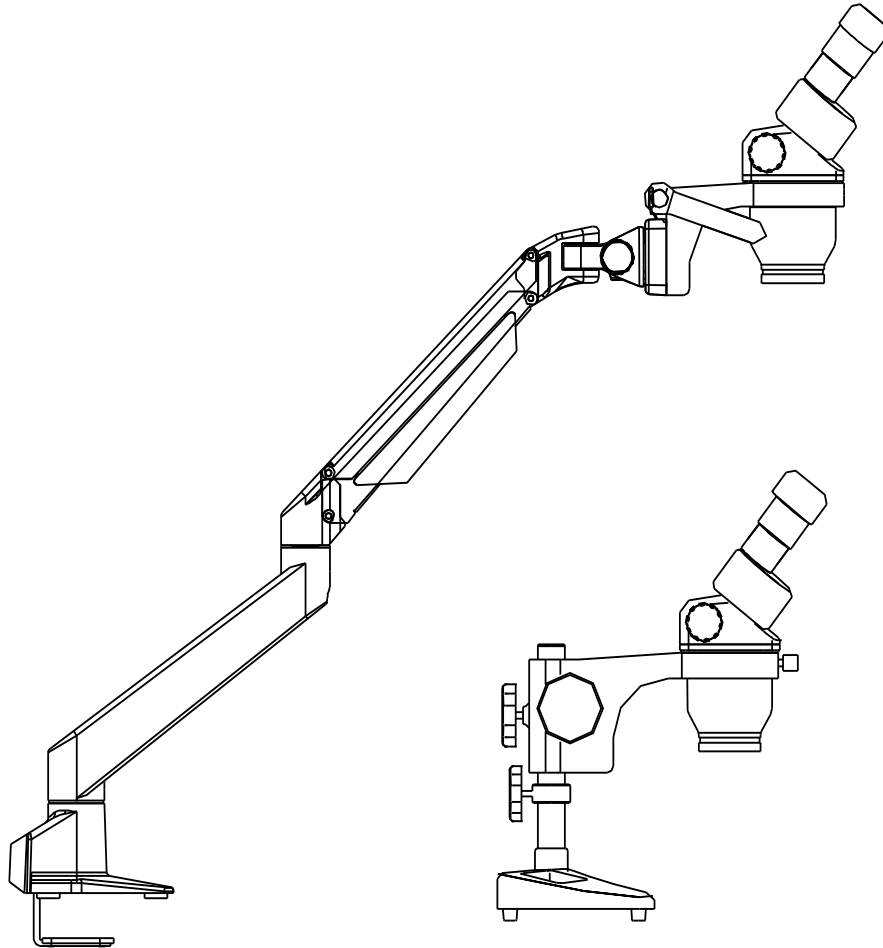

ZUMAX MEDICAL CO.,LTD.

5 Zhiying Street, Suzhou New District, Suzhou, Jiangsu, China 215129

Tel: +86 512 66650100 ext. 510/502/504

Fax:+86 512 66909655

<http://www.zumaxmedical.com>

Preface

Thank you for purchasing our ZSM Series of Dental Lab Microscopes. To prevent damage to your product or injury to yourself or to others, read the following precaution in their entirety before using this equipment. Keep these instructions where all those who use the product will read them.

Precaution

1. **As the microscope is a piece of precision equipment. Always handle with care, avoiding abrupt movement or impact during transportation or operation of controls.**
2. **Avoid exposure to direct sunlight, high temperature and humidity, dust and vibration.**
3. **Avoid leaving dirt or fingerprints on the lens surfaces, as a dirty mirror or lenses may reduce image clarity.**
4. **Clean all glass components by wiping gently with gauze. To remove fingerprints or oil smudges, wipe with gauze slightly moistened with a mixture of ether (70%) and alcohol (30%).**
5. **Since solvents such as ether and alcohol are highly flammable, they must be handled carefully. Be sure to keep these chemicals away from open flames or potential sources of electrical equipment that is being switched on or off. Also remember to always use these chemicals only in a well-ventilated room.**
6. **Do not use organic solutions to wipe the surface of other components. Should be cleaned with a neutral detergent.**
7. **Never attempt to disassemble the microscope as decreased performance may result.**
8. **When not in use, be sure to cover the microscope with the dust cover provided, and store in an area free from moisture to prevent rust.**
9. **The power supply network should contact ground reliably.**



Contents

1 ASSEMBLY.....	1
2 BASIC DATA.....	5
3 OPERATION.....	6
4 OPTIONAL ACCESSORIES.....	7
5 ACCESSORIES ASSEMBLE PROCESS.....	8
6 TROUBLE SHOOTING GUIDE.....	8

1 ASSEMBLY

1.1 Assembly for ZSM100A /ZSM100B

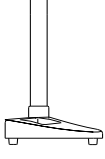
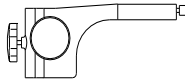
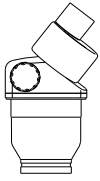





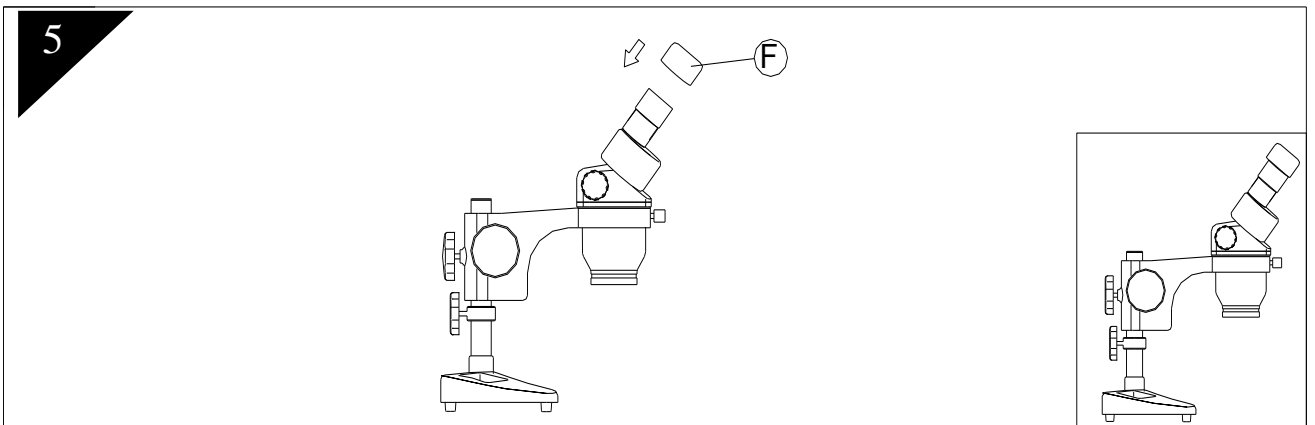
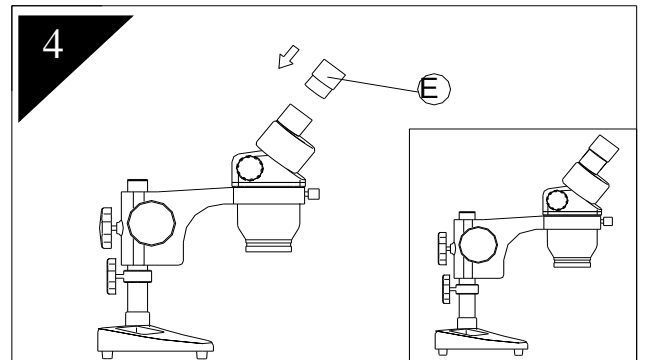
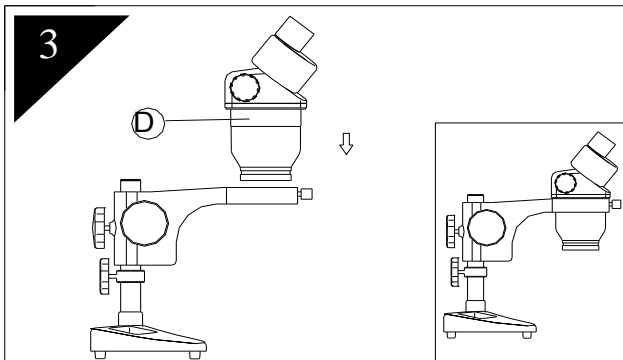
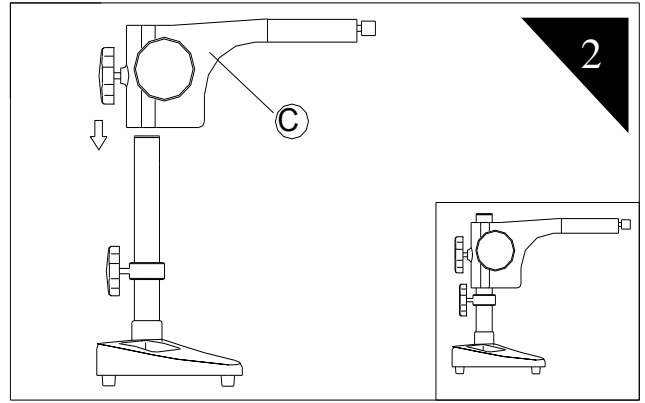
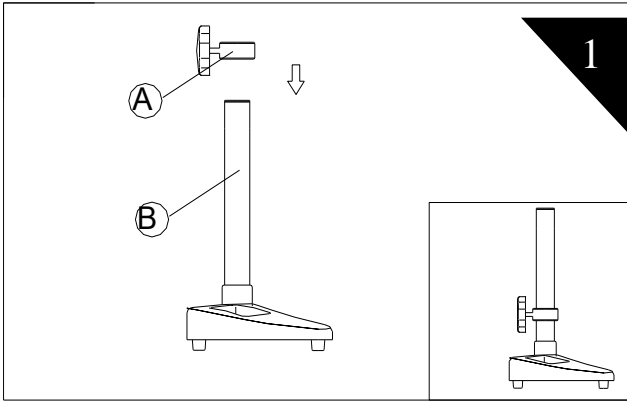



1.1.1 Part list ZSM100A



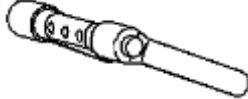

NO.	ITEM	SPECS	QUANTITY
A			1
B			1
C			
D			
E			
F			

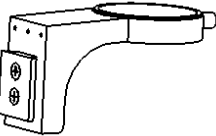
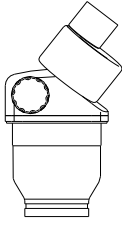
1.1.2 Assembly process ZSM100A



1.1.3 Part list ZSM100B

NO.	ITEM	SPECS	QUANTITY
A			1
B			1
C			
D		M8*90	
E			
F			
G			
H		M4*10	
I			
J			
K			
L			

M		M6	
N		M4	
O		M3	
P		M8*160	

1.1.3 Assembly process ZSM100B

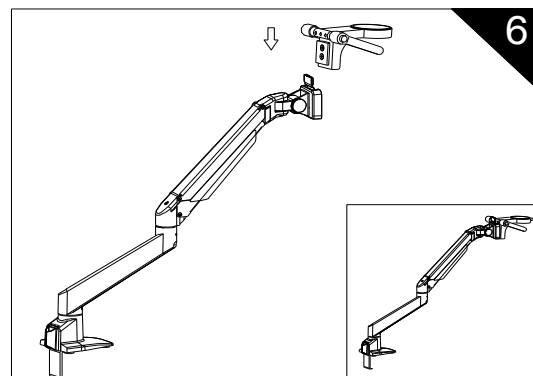
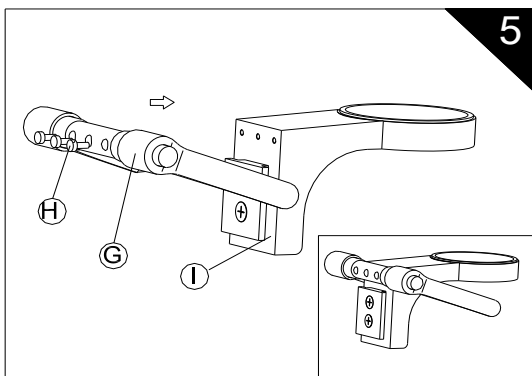
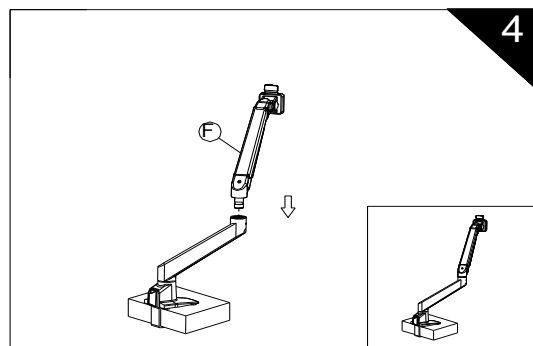
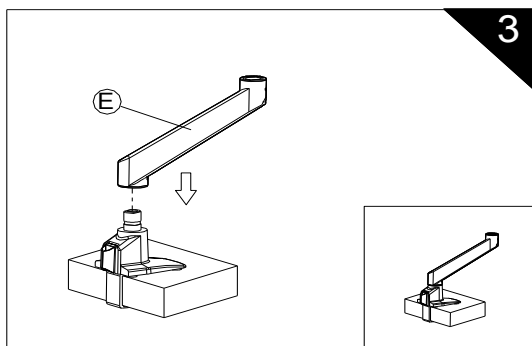
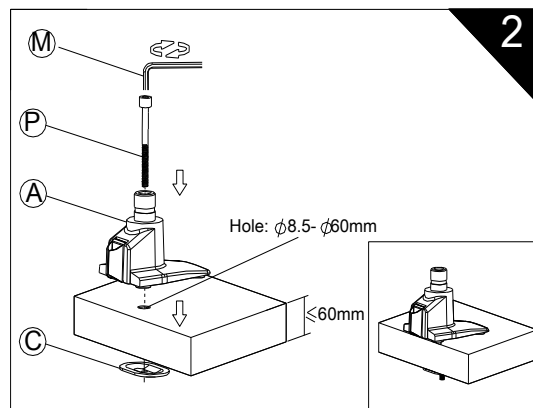
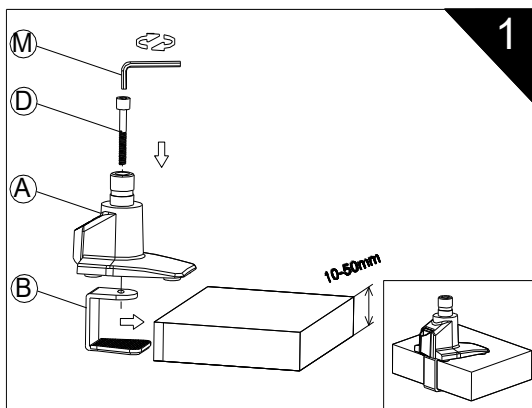

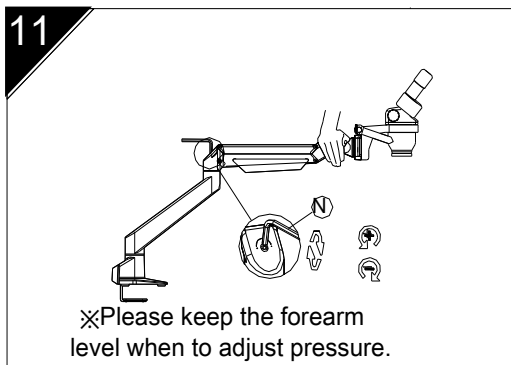
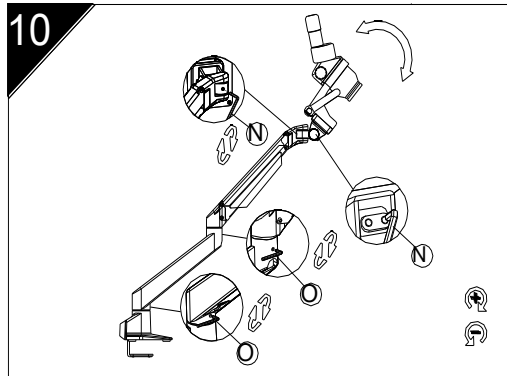
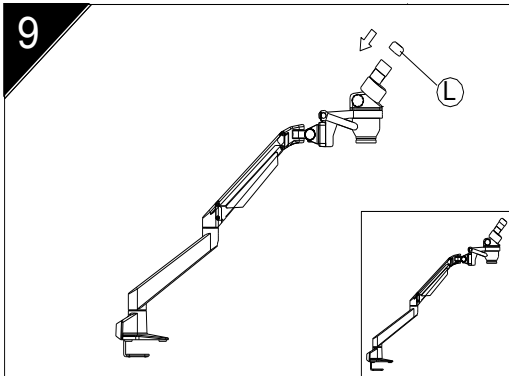
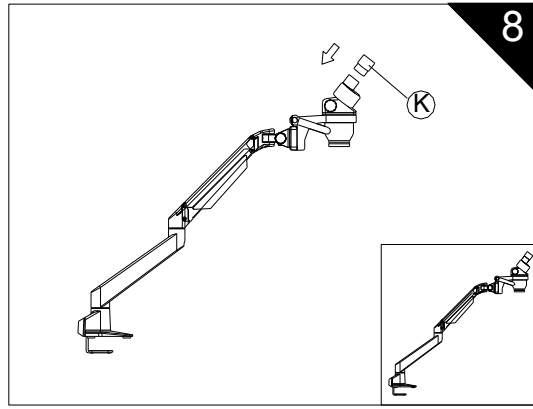
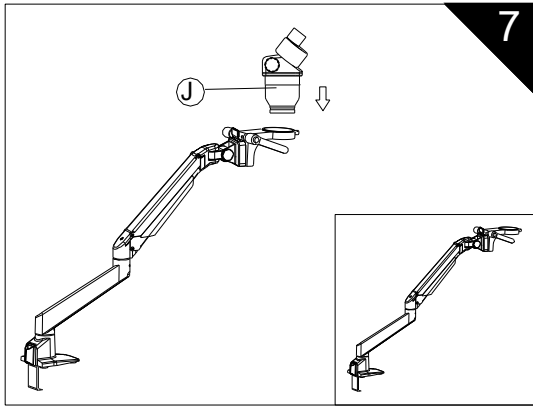

2 BASIC DATA

Model		ZSM100A	ZSM100B
Description			
Microscope main body	Magnification	1X, 2X	
	Zoom ratio	1: 2	
	Working distance (mm)	105	
	Observation tube inclination	45°	
	Eyepieces (10X)	Field of view: Φ 23mm	
	Interpupillary distance adjustment	Adjustment range: 52mm~75mm (10X)	

	Diopter adjustment	Provided on left eyepiece tube only	Provided on both eyepiece tubes
	Magnification adjustment	Magnification with both handwheels in horizontal direction Rotating	
Stand	Microscope main body mount	The measurement to match between the support and the main body is $\Phi 76\text{mm}$	
	Focusing	Rack-and-pinion drive on ball bearing guides, focusing range: 51mm	
	Stage plate	$\Phi 95\text{mm}$ frosted white on one side and black on the other side.	
	Stage clip	Pressed down from above	

3 OPERATION

3.1 Move the microscope to a vertical position above the specimen;

3.2 Pull the Porro prism base slightly with both hands(fig.1) to adjust the distance of the eyepieces to your interpupillary distance;

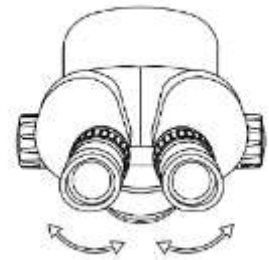

Fig. 1

3.3 Set the microscope to minimum magnification by turning the magnification control knobs. Set the diopter setting ring to minimum(ps. ZSM100A only have the left diopter setting ring) (fig. 2);

3.4 Focusing

3.4.1 Look through the eyepieces, focus the image by turning the focusing knobs(fig. 3).

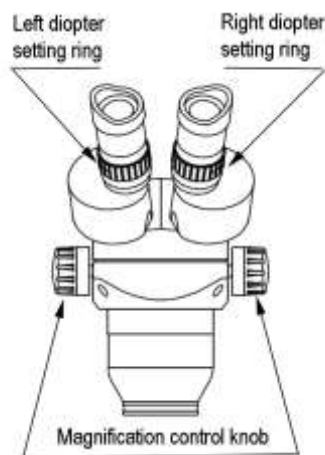

Fig. 2

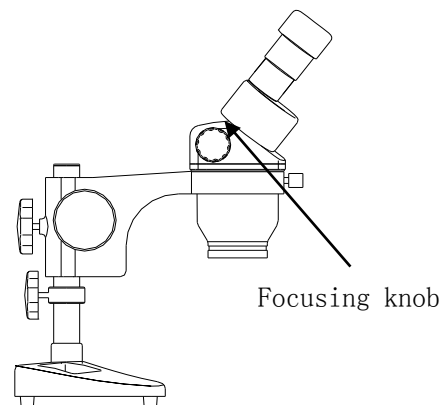

Fig. 3

3.4.2 For ZSM100B: Look through the eyepieces, adjust the microscope level by the handles(fig. 4) to focus the image;

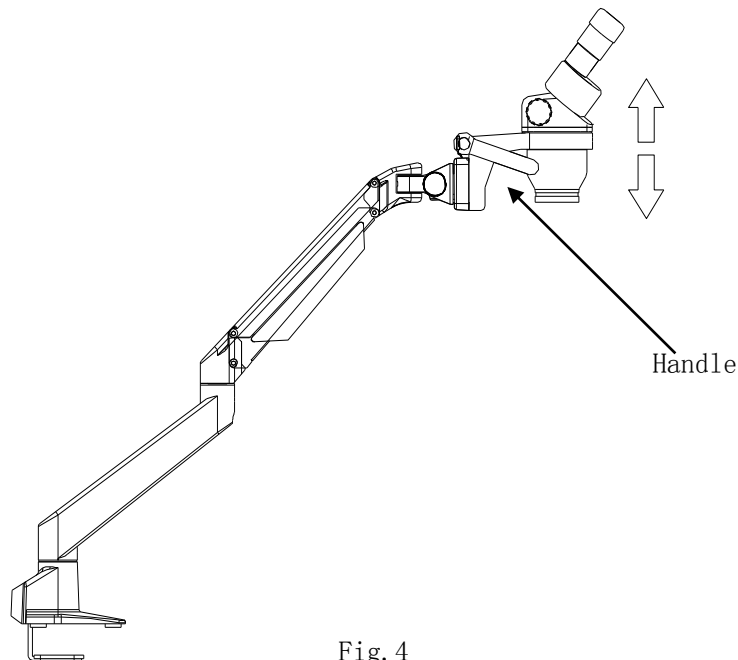

Fig. 4

- 3.5 Set the microscope to maximum magnification and adjust the fine focusing-system (like 3.4.1 or 3.4.2) until the image is sharply defined;
- 3.6 Then reset the microscope to minimum magnification without changing the working distance.
- 3.7 Set the diopter setting ring to the maximum plus value.
- 3.8 Look through the eyepiece and turn the diopter setting ring slowly towards the minus value until the image is sharply defined.

4 OPTIONAL ACCESSORIES

Name	Amount
SWF10X/23mm Eyepiece per pair	1
SWF10X/23 Reticle Eyepiece (OCM10/100X) per piece	1
SWF10X/23 Reticle Eyepiece (OCM10/100X) per piece	1
WF20X/15mm Eyepiece per pair	1
WF30X/9mm Eyepiece per pair	1
Additional objective 0.37X	1
Additional objective 0.5X	1
Additional objective 0.7X	1
Additional objective 1.5X	1
Protective Lens 1X	1
Rubber Eyeguard per pair	1
1X CCD Adapter	1
0.5X CCD Adapter	1
0.3X CCD Adapter	1
LED Light Source	1

5 ACCESSORIES ASSEMBLE PROCESS

5.1 CCD & Camera adapter assembly.



6 TROUBLE SHOOTING GUIDE

NO.	Symptom	Cause	Remedy
1	Incomplete binocular vision	The interpupillary distance is not adjusted correctly.	Correct the interpupillary distance.
		Diopter adjustment is incomplete.	Complete diopter adjustment.
		The right and left eyepieces are different.	Replace and mount the same eyepieces.
2	Stains or dust are observed on the field of view.	Stains or dust have accumulated on the specimen.	Clean thoroughly
		Stains or dust have accumulated on the eyepieces.	Clean thoroughly